



**Communication
Automation
Corporation**

1180 McDermott Dr ♦ West Chester, PA 19380-4022

Tel: (610) 692-9526 ♦ Toll-free: (800) 367-6735 ♦ Fax: (610) 436-8258 ♦ <http://www.cacdsp.com> ♦ Email: sales@cacdsp.com

ETC12™

Audio Interface for the ETPhone™ System

**Mezzanine Board
Technical Reference
Version 0.0**

email: support@cacdsp.com

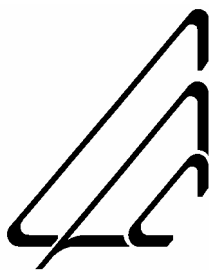

© 2001- 2004 Communication Automation Corporation
West Chester, PA (USA)

License Agreement

The international copyright laws that pertain to computer software and hardware protect this Software/Hardware. It is illegal to duplicate the design and implementation of the Hardware and/or to make copies of the Software except as provided in this license agreement. It is illegal to give copies of CAC Software to another person, or to duplicate the Software by any other means, including electronic transmission, except as provided in this license agreement. CAC Software and Hardware contains trade secrets and, to protect them, you may not decompose, reverse engineer, disassemble, or otherwise reduce the applicable object code or binary portions of the Software or Hardware to human perceivable form.

Our software is a product of Communication Automation Corporation (CAC) and is licensed for unrestricted use WITH CAC HARDWARE PRODUCTS ONLY. CAC software may be reproduced and used by the customer only if this legend is included on all distribution media and this legend is included as a part of the software comments, whether the CAC software is used in whole or in part.

Users may copy or modify CAC software without royalty, but are not authorized to license, sub-license, or distribute this copied or modified CAC software to any other person or organization except as part of a hardware product or software developed by the user that incorporates CAC hardware products. You are permitted, however, to freely distribute your own derived software that communicates to the CAC boards through these software drivers and libraries, free of any royalty to CAC.

Warranty

Communication Automation Corporation reserves the right to make changes to these products, including any software and/or hardware described herein, without notice. No warranty of merchantability or fitness for a particular purpose is expressed or implied. CAC shall not be held liable for incidental or consequential damages in connection with, or arising out of, the use of this Software. CAC does not recommend the use of any of its products, Software or Hardware, for medical or life support applications wherein a failure or malfunction of the product may threaten life or cause injury and will not knowingly license or sell its products for either such use. No rights under any patent accompany the sale of any such products.

Trademarks

GNUPro is a registered trademark of Cygnus Solutions.

ETPhone™ and ETC12™ are trademarks of Communication Automation Corporation.

MIPS is a registered trademark of MIPS Technologies, Inc.

POSIX is a registered trademark of the Institute of Electrical and Electronics Engineers, Inc.

MS-DOS, Windows95, WindowsNT and Windows are registered trademarks of Microsoft Corporation in the United States of America and other countries.

QuicKit Telephony® and smPCI® are registered trademarks of Communication Automation Corporation.

SCSA is a registered trademark of Dialogic Corporation.

SPARC, SunOS and Solaris are registered trademarks of Sun Microsystems Computer Corporation and SunSoft.

Unix is a registered trademark of Santa Cruz Operations.

VME and VMEbus are registered trademarks of Motorola, Inc.

Use of a term in this manual should not be regarded as affecting the validity of any trademark or service mark.

Table of Contents

1.	ETC12 AUDIO INTERFACE FOR THE ETPHONE SYSTEM.....	1-5
1.1	ETPhone ETC12 Overview	1-5
1.1.1	ETC12 Introduction.....	1-5
1.1.2	ETC12 Top Level Description.....	1-7
1.2	ETC12 Hardware Specification	1-7
1.2.1	ETPhone Mezzanine Interface.....	1-7
1.3	ETC12 CODECS	1-9
1.3.1	ETPhone ETC12 System Audio Signals.....	1-10
1.4	Display LEDs	1-12
1.5	Voltage and Temperature Sensor.....	1-12
1.6	Mechanical Characteristics	1-12
1.7	Power Consumption	1-12
1.8	Software.....	1-12
1.9	Reference Documents.....	1-12

TABLES

Table 1-1: ETPhone Mezzanine Connector Pinout	1-7
Table 1-2: AMP SCSI Connector Pinout	1-11

FIGURES

Figure 1-1: Front Panel ETP112.....	1-5
Figure 1-2: Back Panel ETP112	1-6
Figure 1-3: ETC12 Block Diagram	1-7
Figure 1-4: CODEC Channel Gain Stages.....	1-9
Figure 1-5: AMP SCSI connector	1-10

1. ETC12 AUDIO INTERFACE FOR THE ETPHONE SYSTEM

1.1 ETPhone ETC12 Overview

1.1.1 ETC12 Introduction

This document specifies the characteristics of the ETC12, an ETPhone mezzanine board, with six Texas Instruments TLV320AIC23B CODECs with a total of 12 stereo audio channels, its memory, and the software libraries and drivers to support this board.



Figure 1-1: Front Panel ETP112

The front panel provides access to the following:

MMC Card	Additional Mountable File System
Head Phone	Channel 0 (LEFT) and Channel 1 (RIGHT) Output
Line In	Channel 0 (LEFT) and Channel 1 (RIGHT) Input
Microphone In	Mono Input
ETC12 Audio	12 Addition Audio Channels (See Pinout Below)
Control/Volume	Not Yet Supported



Figure 1-2: Back Panel ETP112

12 Volt Power Input	Power Supply Input
RS232	Serial Interface to/from ETPhone Foundation Board
E1/T1	Telecom Interface
USB	Supported in Future Releases as alternative interface
100BT	2-port Ethernet Switch

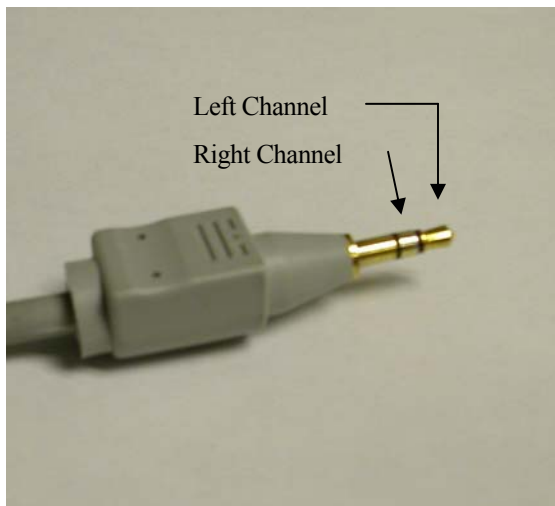

Figure 1-3: Audio Connector

1.1.2 ETC12 Top Level Description

The ETC12 is a mezzanine board for the ETPhone system. It contains the following major functional blocks:

An ETPhone mezzanine bus interface

Six TLV320AIC23B CODECs with a total of 12 stereo audio channels

A RISC Bus connecting serial ports of the Xilinx® Spartan-IIe FPGA and other resources in the ETPhone system

A McBSP Interface connecting ETPhone's DSP to the FPGA and the CODECs.

2 LEDs under FPGA program control

A global programmable frequency generator

A 64K x 8 EEPROM (for debug only)

A temperature sensor

Software for Solaris, Windows 2000 and XP are provided, together with a software interface library to allow access to and control of the ETC12 from user-developed programs.

Diagnostics are provided which are sufficient to verify correct operation of all functional blocks on the ETC12.

TO DO

Figure 1-3: ETC12 Block Diagram

1.2 ETC12 Hardware Specification

The electrical hardware portions of the characteristics in Section 3 are elaborated in the following subsections.

1.2.1 ETPhone Mezzanine Interface

The ETPhone mezzanine connector provides the basic communication path between the baseboard and mezzanine board(s). Signals used by the ETC12 are grouped by function and discussed in subsequent sections.

Table 1-1: ETPhone Mezzanine Connector Pinout

Pin Number	Pin Name	I/O	Pin Number	Pin Name	I/O
1	+12V		2	+12V	
3	N/C		4	N/C	
5	RISC_TDMIN	I/O	6	GND	
7	RISC_TDMFRAME	I/O	8	TDM_MEZZ_CLK	O
9	GND		10	RISC_TDMOUT	I/O
11	RISC_TDMTEN	I/O	12	FPGA_BUSY/ MEZZ_CLK2	I/O
13	FPGA_DONE	I/O	14	GND	
15	FPGA_INIT_N/ MEZZ_CLK1	I/O	16	FPGA_PROGRAM_N	I/O

17	+3.3V		18	ATM_OUTP8	O
19	ATM_OUTP9	O	20	ATM_OUTP6	O
21	ATM_OUTP7	O	22	GND	
23	ATM_OUTP5	O	24	ATM_OUTP4	O
25	GND		26	ATM_OUTP2	O
27	ATM_OUTP3	O	28	ATM_OUTP0	O
29	ATM_OUTP1	O	30	GND	
31	ATM_INP11	I	32	ATM_INP10	I
33	GND		34	ATM_INP8	I
35	ATM_INP9	I	36	ATM_INP6	I
37	ATM_INP7	I	38	+3.3V	
39	ATM_INP5	I	40	ATM_INP4	I
41	GND		42	ATM_INP2	I
43	ATM_INP3	I	44	ATM_INP0	I
45	ATM_INP1	I	46	GND	
47	ATM_IOP1	I/O	48	ATM_IOP0	I/O
49	+3.3V		50	BCLKX2	I/O
51	BFSX2	I/O	52	BFDR2	I/O
53	BDR2	I	54	GND	
55	MEZZ_INT	I	56	BDX2	O
57	GND		58	RISC_BUF_RWN	O
59	BCLKR2	I/O	60	FPGA_CSN_N	I/O

Table 1-1 - ETPhone Mezzanine Connector Pinout (continued)

Pin Number	Pin Name	I/O	Pin Number	Pin Name	I/O
61	RISC_BUF_BWEN0	O	62	GND	
63	RISC_BUF_BWEN1	O	64	RISC_BUF_OEN	O
65	GND		66	RISC_BUF_A23	O
67	WARM_RESETN	O	68	RISC_BUF_A21	O
69	RISC_BUF_A22	O	70	+3.3V	
71	RISC_BUF_A20	O	72	RISC_BUF_A19	O
73	GND		74	RISC_BUF_A17	O
75	RISC_BUF_A18	O	76	RISC_BUF_A15	O
77	RISC_BUF_A16	O	78	GND	
79	RISC_BUF_A14	O	80	RISC_BUF_A13	O
81	GND		82	RISC_BUF_A11	O
83	RISC_BUF_A12	O	84	RISC_BUF_A9	O
85	RISC_BUF_A10	O	86	GND	
87	RISC_BUF_A8	IO	88	RISC_BUF_A7	O
89	GND		90	RISC_I2C_SDA	I/O
91	RISC_BUF_A6	O	92	RISC_BUF_A5	O
93	RISC_I2C_SCL	O	94	GND	
95	RISC_BUF_A4	O	96	RISC_BUF_A3	O
97	+3.3V		98	RISC_BUF_A1	O
99	RISC_BUF_A2	O	100	RISC_BUF_A0	O
101	RISC_BUF_D15	I/O	102	GND	
103	RISC_BUF_D13	I/O	104	RISC_BUF_D14	I/O

105	GND		106	RISC_BUF_D12	I/O
107	RISC_BUF_D11	I/O	108	RISC_BUF_D10	I/O
109	RISC_BUF_D9	I/O	110	RISC_BUF_D8	I/O
111	RISC_BUF_D7	I/O	112	+3.3V	
113	GND		114	RISC_BUF_D6	I/O
115	RISC_BUF_D5	I/O	116	RISC_BUF_D4	I/O
117	RISC_BUF_D3	I/O	118	RISC_BUF_D2	I/O
119	RISC_BUF_D1	I/O	120	RISC_BUF_D0	I/O

1.3 ETC12 CODECS

This section describes the basic operation of the Texas Instruments TLV320AIC23B CODECs, as they are integrated on the ETC12 mezzanine. Additional details on the operation of the CODECs may be found in the data sheet for the TLV320AIC23B CODEC which is available on CAC's FTP site (<ftp://ftp.cacdsp.com/pub/datasheets/ti/tlv320aic23b.pdf>).

Gain Stages and Analog Characteristics

The figure below shows a functional diagram of the input and output gain stages for each of the 12 analog channels (2 channels per CODEC).

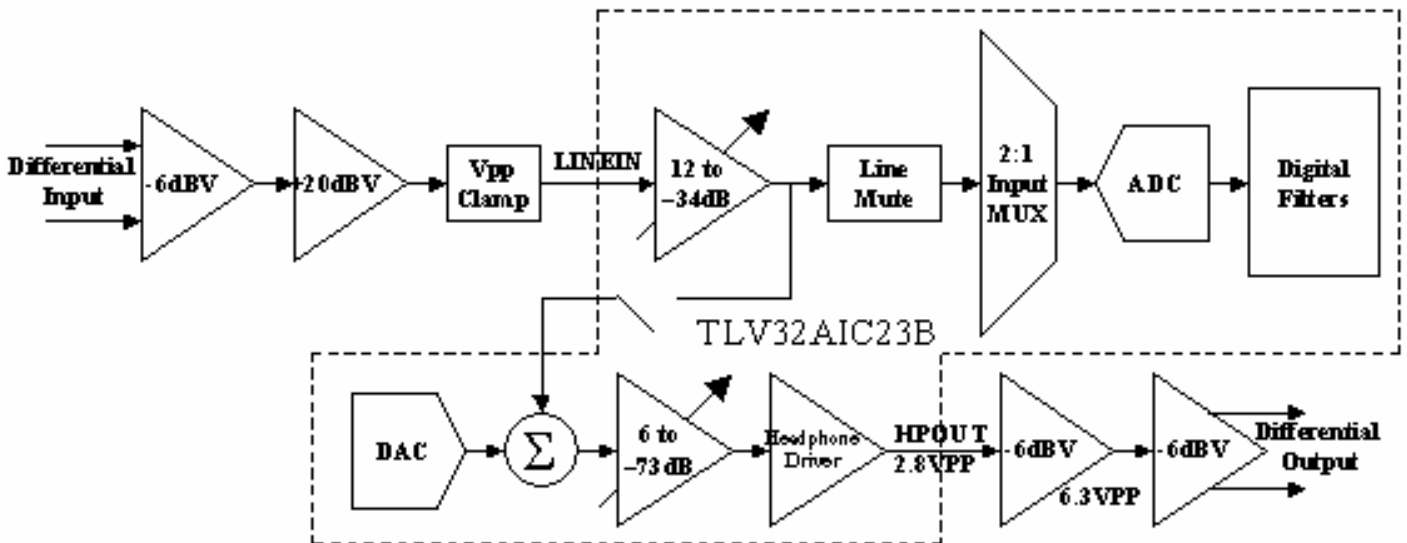

Figure 1-4: CODEC Channel Gain Stages

INPUT CHARACTERISTICS

TO DO

OUTPUT CHARACTERISTICS

TO DO

1.3.1 ETPhone ETC12 System Audio Signals

The input and output audio channels as routed through the ETPhone system are differential, i.e. a pair of wires (+ and -) carry each signal. The numbering of the twelve channels start with 0 and ends with 11. Therefore, the input side of the first channel consists of the signals CIN00+ and CIN00-. Likewise, the outputs are labeled COUT00+ and COUT00-. In addition to the 48 signal wires, there are 19 pins that are either grounded or no-connections and a user-defined CLK signal, making a total of 68-pins. Standard 68-pin SCSI connectors, from AMP and standard 68-pin SCSI cables are used for interconnect of the audio components of the ETPhone system.

Figures 1-7 shows the AMP connector and to locate pin 1 for each type.

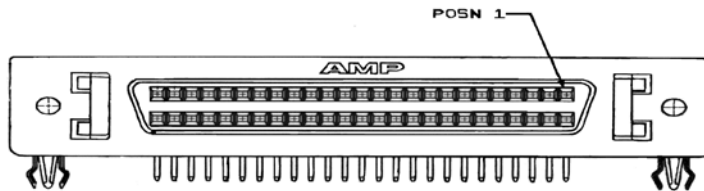

Figure 1-5: AMP SCSI connector

AMP connectors are used between the outside of the rear-panel and the audio patch panel. Standard external SCSI cables with thumbscrews or latches are used to make these connections.

Table 1-2: AMP SCSI Connector Pinout

Pin #	Signal Name	Pin #	Signal Name
1	COOUT00-	35	OUT00+
2	CIN00+	36	CIN 00-
3	COOUT01-	37	COOUT01+
4	CIN 01+	38	CIN 01-
5	GND	39	GND
6	GND	40	GND
7	COOUT02-	41	COOUT02+
8	CIN 02+	42	CIN 02-
9	COOUT03-	43	COOUT03+
10	CIN 03+	44	CIN 03-
11	GND	45	GND
12	COOUT04-	46	COOUT04+
13	CIN 04+	47	CIN 04-
14	COOUT05-	48	COOUT05+
15	CIN 05+	49	CIN 05-
16	NC	50	NC
17	NC	51	NC
18	NC	52	NC
19	NC	53	External CLK
20	COOUT06-	54	COOUT06+
21	GND	55	GND
22	CIN 06+	56	CIN 06-
23	COOUT07-	57	COOUT07+
24	CIN 07+	58	CIN 07-
25	COOUT08-	59	COOUT08+
26	CIN 08+	60	CIN 08-
27	COOUT09-	61	COOUT09+
28	CIN 09+	62	CIN 09-
29	COOUT10-	63	COOUT10+
30	GND	64	GND
31	CIN 10+	65	CIN 10-
32	COOUT11-	66	COOUT11+
33	CIN 11+	67	CIN 11-
34	GND	68	GND

1.4 Display LEDs

The ETC12 has a bicolor status LED controlled by the Xilinx® FPGA. The ETC12 LED shows an green color once the FPGA is programmed.

1.5 Voltage and Temperature Sensor

The ETC12 has a NE1619 Voltage Monitor and temperature sensor. It monitors the +1.8V, +3.3AV, and +10AV supply voltages. The SMBus serial bi-directional data and the serial clock input, SDA and SCL pins are connected to the RISC I²C Bus Interface.

1.6 Mechanical Characteristics

The ETC12 is implemented as a mezzanine in the ETPhone system.

1.7 Power Consumption

The ETC12 requires +12V and + 3.3V. The power consumption requirement depends on the clock speed and the activity on the board. Power consumption has been empirically found to be as follows:

	Supply	Current	Power
ETPhone - ETC12	12V	0.7A	8.4W

1.8 Software

Software for Solaris, Windows XP and Window 2000 are provided, together with a host API to allow access to and control of the ETC12 from user-developed programs. Diagnostics are provided which are sufficient to verify correct operation of all functional blocks on the ETC12.

1.9 Reference Documents

1. Texas Instruments TLV320AIC23B Data Sheet.
2. Xilinx XC2S200E Series FPGA Data Sheet, September 1996.